

SIZE 7SB *Filter/Clone* DUST COLLECTOR (ELECTRIC MOTOR DRIVE)

NOTE: Top Plate and Blower Inlet not shown this view

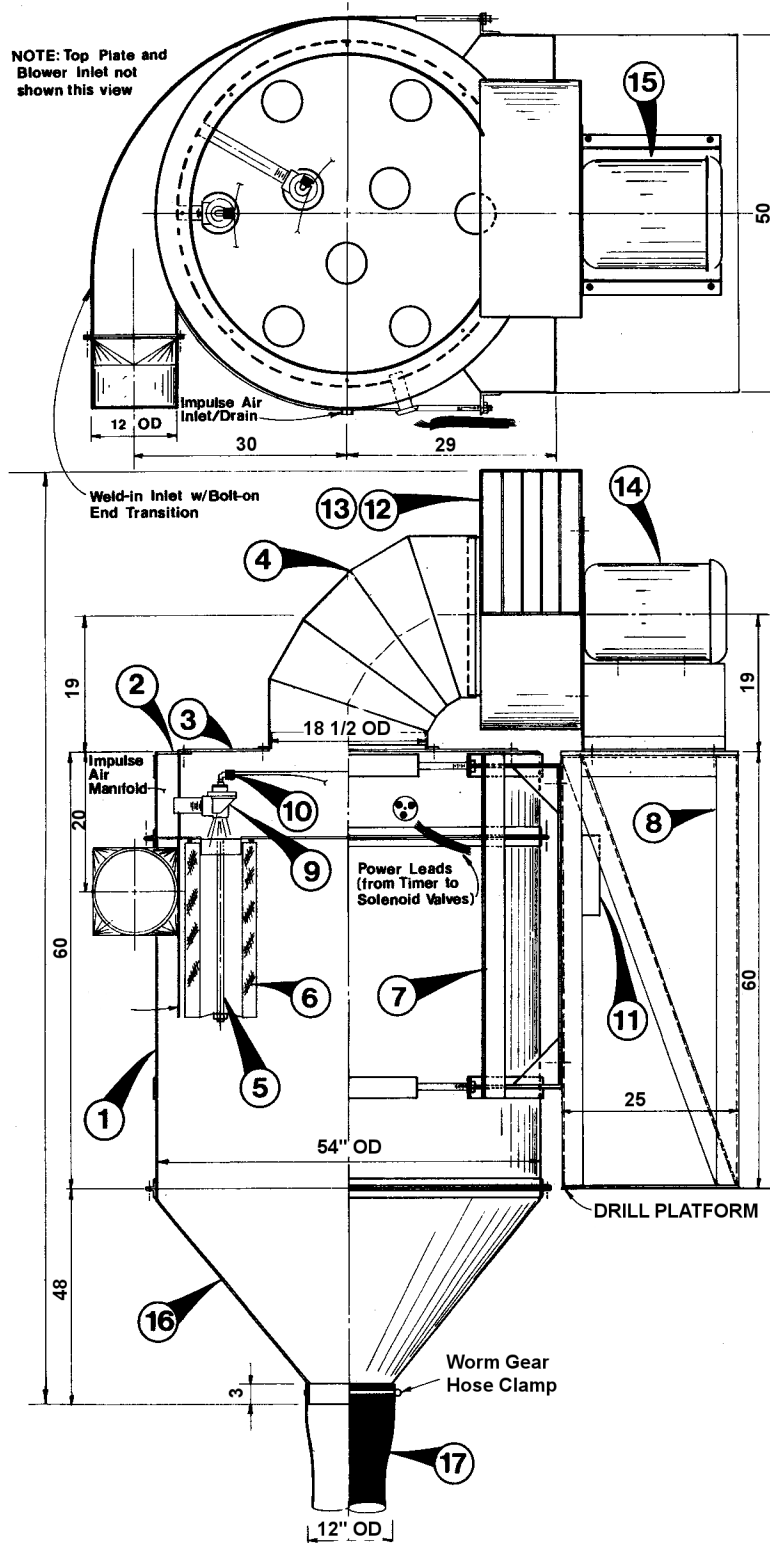

PARTS LIST

Item	Part No.	Qty	Description
1	FC70001L	1	Lower Housing
2	FC70001U	1	Upper Housing
3	FC70001T	1	Housing Top Plate
4	FC700120	1	Dropout Cone
5	FC300020	9	Element Retention
6	FC301001	9	Filter Element
7	FC701010	1	Mounting Saddle
8	FC702030	1	Mounting Frame
9	FC201002	9	Impulse Valve
10	FC501002	1	AC Solenoid Valve
11	ET100000	1	AC Electric Timer
12	BL365100	1	Blower Housing
13	BL365200	1	Blower Wheel
14	Call for P/N	1	25 HP Elec. Motor
15	FC701400	1	Motor Stand
16	FC700140	1	Blower Inlet
17	BL121601	1	Dropout Hose

1. Dust Box Assembly. CUSTOM DESIGNS AVAILABLE TO FIT SPECIFIC DRILLS. INCLUDES HYDRAULIC CYLINDER ASSEMBLIES FOR ADJUSTING DUST BOX HEIGHT, VARIETY OF CURTAIN MATERIALS, AND MULTIPLE SEAL AROUND DRILL PIPE (see dwg below).

2. Suction Hose. HEAVY-DUTY ABRASION RESISTANT RUBBER POLYMER, 12" ID AVAILABLE IN 12.5 FT AND 25 FT LENGTHS.

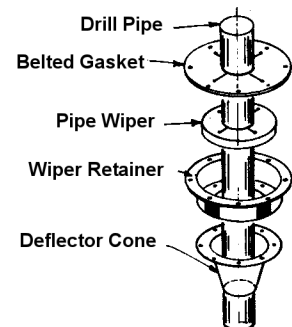

MULTIPLE SEAL