

# SIZE 5SB *Filter/Clone* DUST COLLECTOR (HYDRAULIC MOTOR DRIVE)

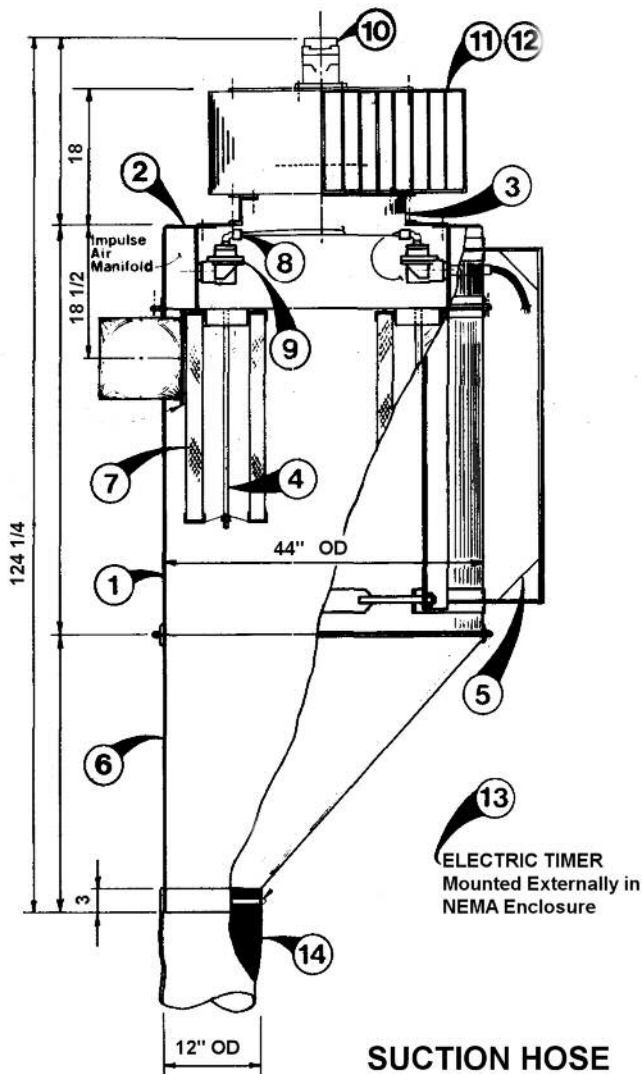
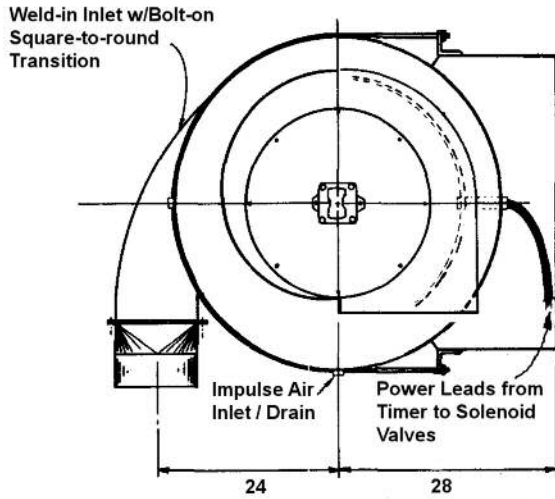

## SUCTION HOSE

- 10" ID or 12" ID Abrasion resistant rubber polymer  
Available in 12.5 ft. and 25 ft. lengths.

## PARTS LIST

Item	Part No.	Qty	Description
1	FC50441L	1	Lower Housing
2	FC50441U	1	Upper Housing
3	FC200013	1	Blower Mount
4	FC300020	7	Element Retention
5	FC504440	1	Mount Saddle
6	FC504412	1	Dropout Cone
7	FC301001	7	Filter Element
8	FC401002	7	DC Solenoid Valve
9	FC201002	7	Impulse Valve
10	FC501005	1	Hydraulic Motor
11	BL365100	1	Blower Housing
12	BT365200	1	Blower Wheel
13	DET09000	1	DC Electric Timer
14	BL121601	1	Dropout Hose

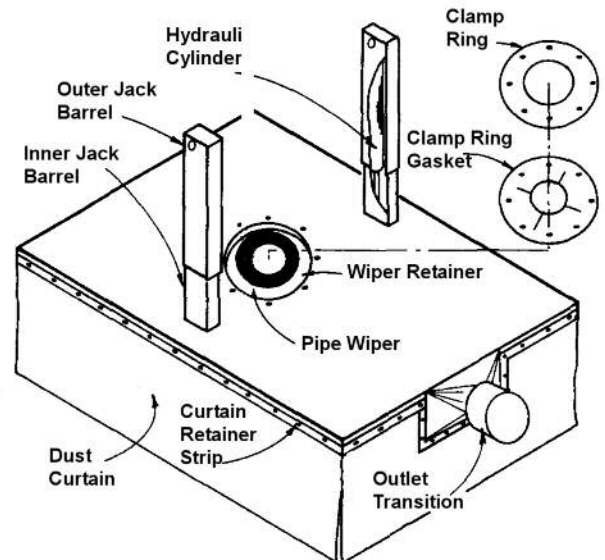

## DUST BOX ASSEMBLY

### NOTES:

1. Alternate hydraulic motors available to meet drill system applications.
2. Pickup pot options available on specific installations where Total Collection is required.