

SIZE 4SB

Filter/Clone DUST COLLECTOR (HYDRAULIC MOTOR DRIVE)

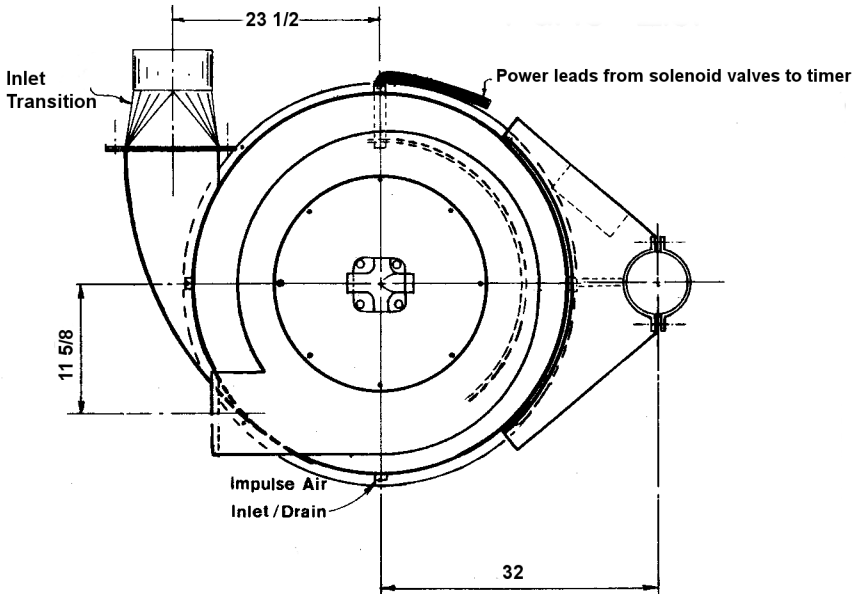

PARTS LIST			
Item	Part No.	Qty	Description
1	FC40001L	1	Lower Housing
2	FC400012	1	Dropout Cone
3	FC200013	1	Blower Mount
4	FC300020	6	Element Retention
5	FC401150	1	Mount Post/Saddle
6	FC40001U	1	Upper Housing
7	FC301001	6	Filter Element
8	FC401002	6	DC Solenoid Valve
9	FC201002	6	Impulse Valve
10	FC401005	1	Hydraulic Motor
11	BT197000	1	Blower Housing
12	BT196000	1	Blower Wheel
13	DET09000	1	DC Electric Timer
14	BL121601	1	Dropout Hose

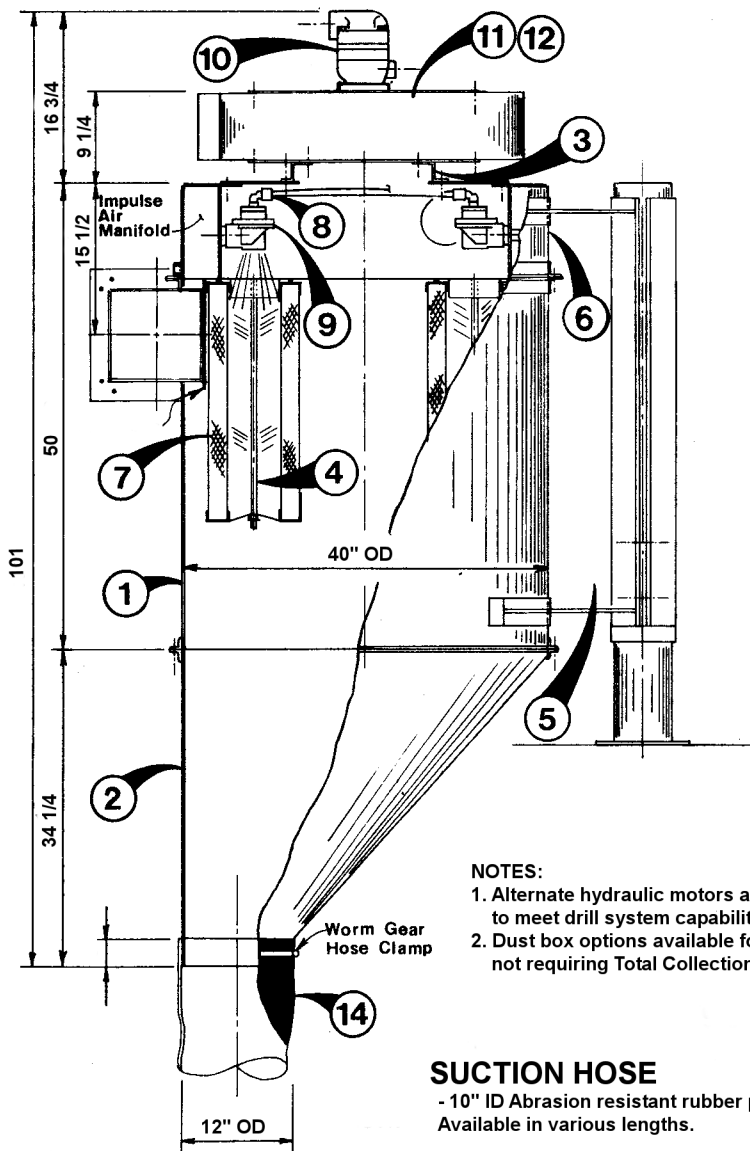

- NOTES:
1. Alternate hydraulic motors available to meet drill system capabilities.
 2. Dust box options available for drills not requiring Total Collection.

SUCTION HOSE
- 10" ID Abrasion resistant rubber polymer
Available in various lengths.

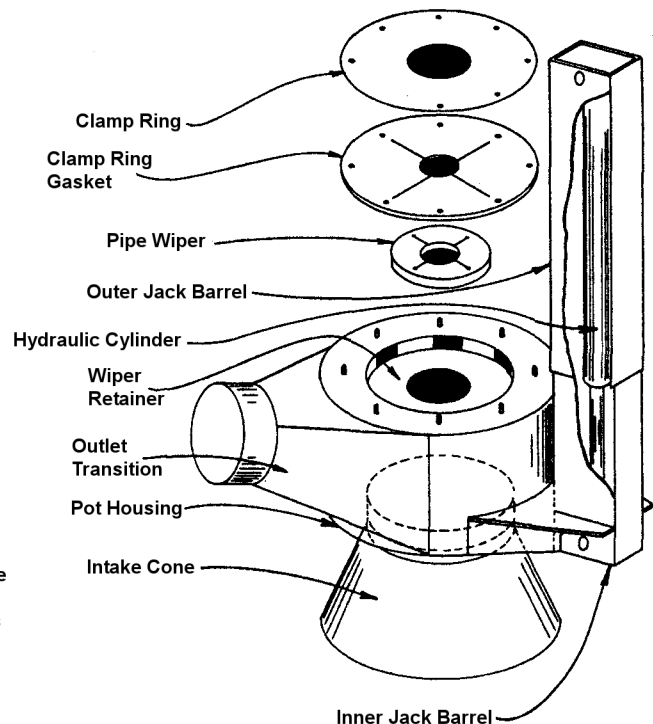

PICKUP POT