

# SIZE 3SB *Filter/Clone* DUST COLLECTOR (HYDRAULIC MOTOR DRIVE)

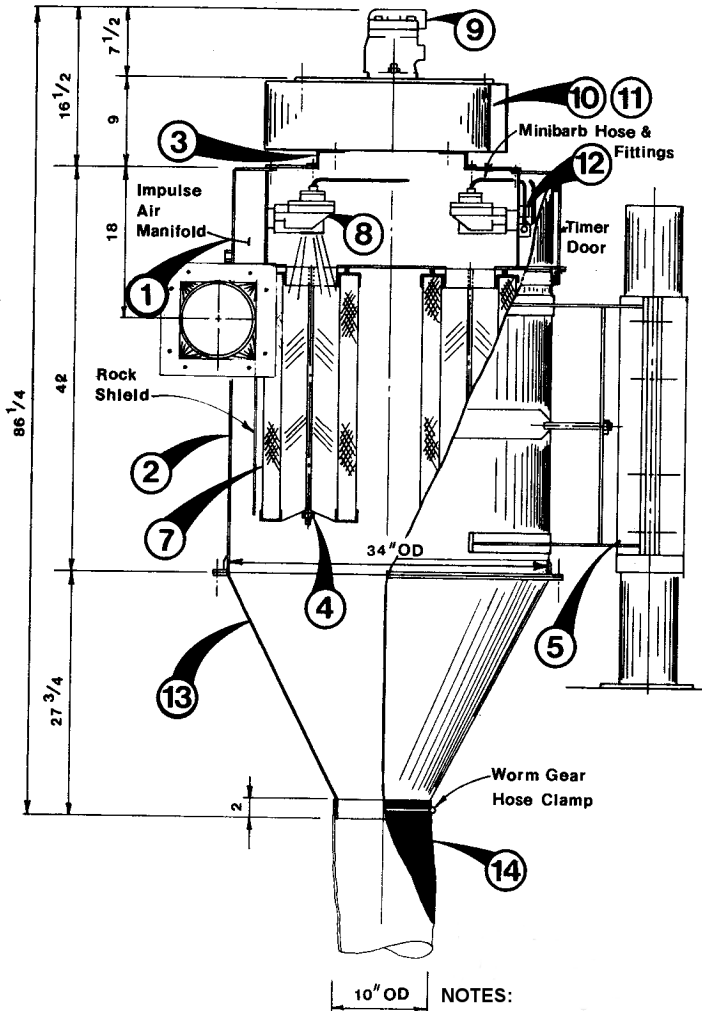
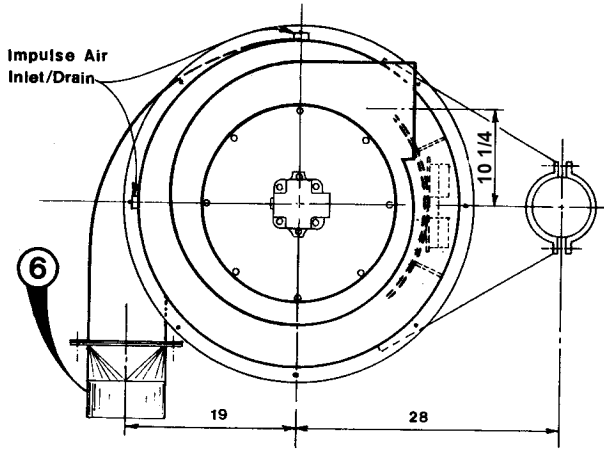

- NOTES:
1. Alternate hydraulic motors available to meet drill system capabilities.
  2. Dust box options available for drills not requiring Total Collection.

**SUCTION HOSE** - 8" ID Abrasive resistant rubber polymer.  
Available in various lengths.

## PARTS LIST

Item	Part No.	Qty	Description
1	FC30001U	1	Upper Housing
2	FC30001L	1	Lower Housing
3	FC200013	1	Blower Mount
4	FC300020	4	Element Retention
5	FC301150	1	Mount Post/Saddle
6	FC301231	1	Inlet Transition
7	FC301001	4	Filter Element
8	FC201002	4	Impulse Valve
9	FC301005	1	Hydraulic Motor
10	BT206000	1	Blower Housing
11	BT205000	1	Blower Wheel
12*	AT100000	1	Pneumatic Timer
12*	DET09000	1	Electric Timer
14	FC300012	1	Dropout Cone
15	BL101601	1	Dropout Hose

\* Customer can choose between pneumatic or electric timer.

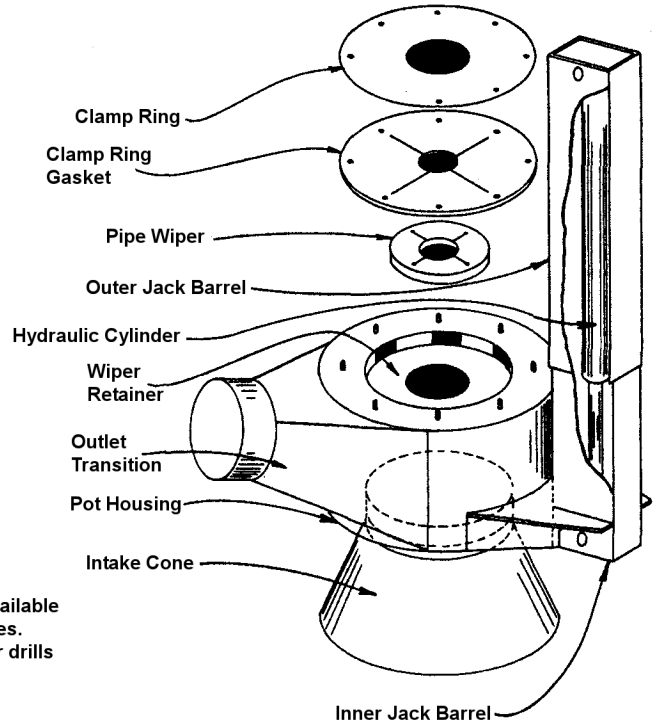

## PICKUP POT